

Attached are JELD-WEN's recommended installation instructions for bi-fold doors using 20 or 30 pound hardware kits. Read these installation instructions thoroughly before beginning. They are designed to work in most existing applications. However, existing conditions may require changes to these instructions. If changes are needed, they are made at the installer's risk. For installations other than indicated in these instructions, contact a building professional.

Note to Installer: Provide a copy of these instructions to the building owner. By installing this product, you acknowledge the terms and conditions of the limited warranty as part of the terms of the sale.

GLOSSARY

Finished Opening

The resulting opening after any trim work is completed. Measure these dimensions for proper door fitting.

Lead Door

The panel or section without the pivoting hardware. On four panel assemblies, these are the two that meet in the middle.

Pivot Door

The panel or section that contains the pivoting hardware and supports the weight of the door assembly.

SAFETY AND HANDLING

- Read and fully understand ALL manufacturers' instructions before beginning.
- Wear protective gear (e.g. safety glasses, gloves, ear protection, etc.).
- Store doors in a dry, well-ventilated building and on a flat and level surface. Allow doors to acclimate to local conditions for at least 24 hours before finishing.
- Do not subject doors to extremes of heat and/or humidity. Prolonged exposure may cause damage. Buildings where humidity and temperature are controlled provide the best storage facilities (recommended conditions 30%-50% Relative Humidity and 50°F to 90°F).
- Do not install doors in buildings that have wet plaster or cement unless they have been properly finished. Do not store doors in buildings with excessive moisture content - HVAC systems should be operating and balanced. Avoid sudden changes such as forced heat to dry out a building. Doors should not be delivered to the job site or installed until concrete floors, foundation, plaster or drywall are cured.
- Doors should always be handled with clean hands or while wearing clean gloves.
- Doors should be lifted and carried when being moved, not dragged across one another. Use safe lifting techniques.

IF INJURY OCCURS, IMMEDIATELY SEEK MEDICAL ATTENTION!

FINISHING

These are guidelines for finishing doors. For more detailed instructions see our Door Finishing document at www.jeld-wen.com/resources or visit a local paint professional.

- Clean the door with a clean, lint-free cloth, removing all dust and foreign debris.
- Finish all six sides (both sides and all four edges) of the door slab, including cutouts for hardware. Failure to finish all six sides may result in the denial of warranty claims for operational or performance problems.
- Use a good quality primer and paint, or wood sealer and stain. Pre-primed products do not need to be re-primed. Use one manufacturer's products to ensure compatibility and follow all manufacturers' application instructions.

INSPECT DOOR AND OPENING

- Cosmetic damage, correct product (size, color, design, etc.)
- Measure height and width of finished wall opening. Width must be 1/2" larger than the bi-fold size. Height must be approximately 1 1/2" taller. If shorter, the bi-fold doors cannot be installed. If higher, shorten by nailing a wood strip at the top of the opening.
- Doors may be trimmed 1/4" on each side if necessary.

NEEDED TOOLS AND MATERIALS

- Measuring tape
- Hammer
- Drill with bits
- #2 Phillips screwdriver
- Safety glasses
- Finishing supplies

PARTS INCLUDED

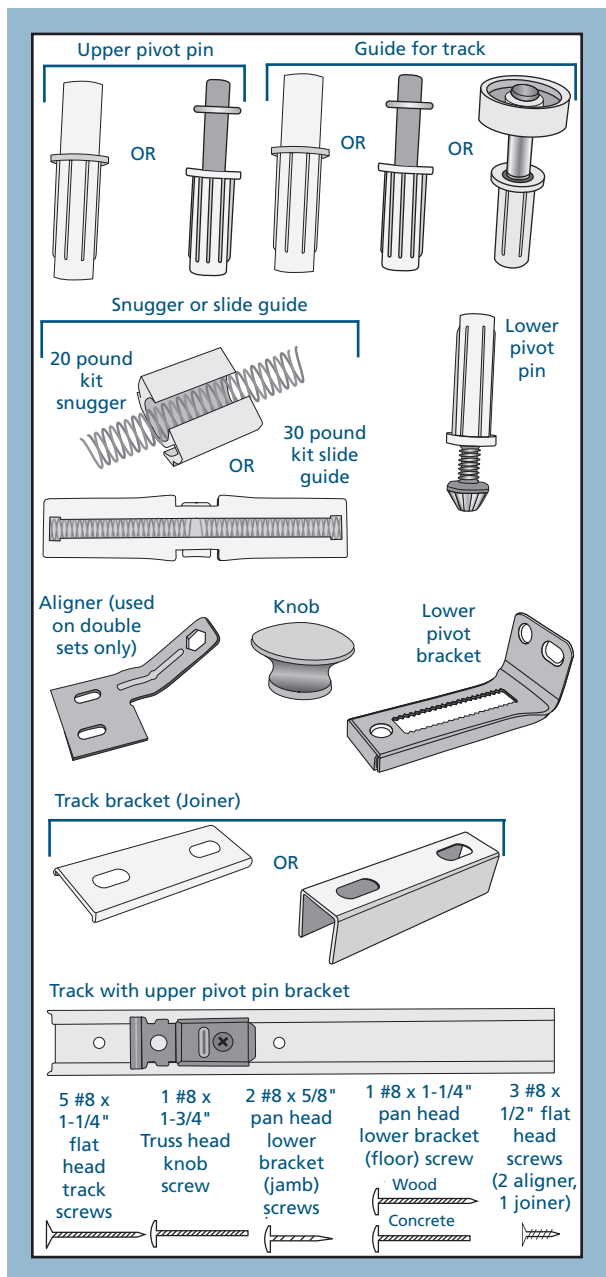

INSTALLATION

1. Using a hammer, gently tap pivot pins and guide into the pre-drilled holes in the locations shown.

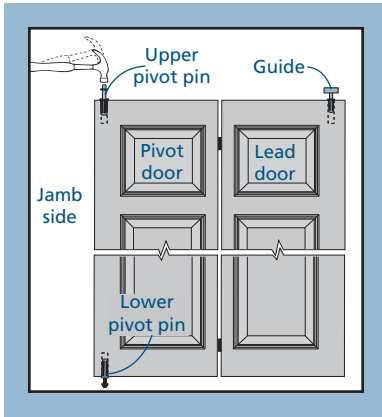

2. Position overhead track in the opening with the open side down and the bracket end toward the jamb. Center the track in the finished opening, or allow at least 3/4" between the track and the front of the finished opening. Secure the track with the #8 x 1 1/4" flat head screws through the pre-drilled holes until snug. If installing four panels with two tracks, use a track bracket between the two ends in the center.

3. Position the lower bracket on the floor in line with overhead track. The bottom of the bracket must rest securely on the floor or carpet. Fasten to the jamb and floor with the provided screws as shown.

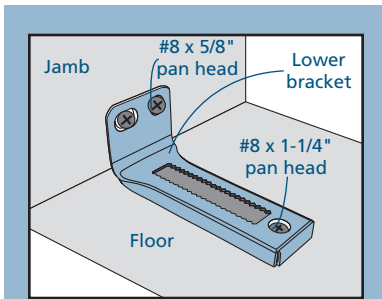

4. Place the upper pivot pin in the hole in the bracket and the guide in the track (or in the middle of the slide guide between the springs). Lift the door assembly slightly and drop the lower pin into the lower bracket slot.

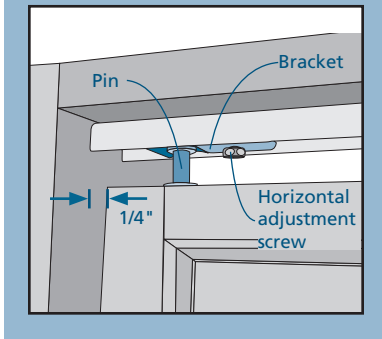

5. Verify there is a 1/4" clearance between the pivot door and the jamb. Four panel assemblies should be snug at the middle. If adjustments are necessary, door panels should be folded, in some cases removed, to gain access to the adjustment screws.

To adjust horizontally:

6. At the top, loosen the screw in the top pivot bracket and move toward or away from the jamb until there is 1/4" clearance. Retighten.
7. At the bottom, lift assembly and move the adjusting wheel toward or away from the jamb until doors are parallel with jamb, then lower into bracket.

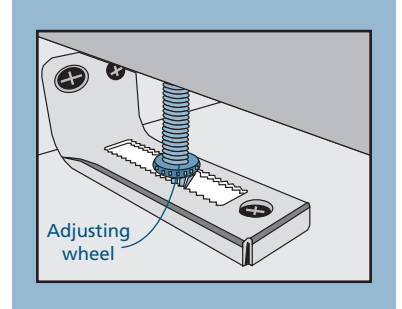

To adjust vertically:

8. Lift assembly slightly until the adjustment wheel clears the slot in the lower bracket. Rotate the adjustment wheel to the left to raise doors or to the right to lower them. Be sure the teeth lock firmly into bracket when finished.
9. Snap the snugger into the lead door end of the track, or between guides in a four door installation.
10. For four door configurations, fasten an aligner with the #8 x 1/2" flat head screws as shown on the back side of each lead door.

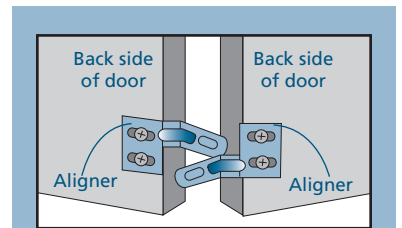

11. To install the door knob, drill a hole, slightly smaller than the provided screw, in the center of the middle rail of the lead door(s) and attach knob.

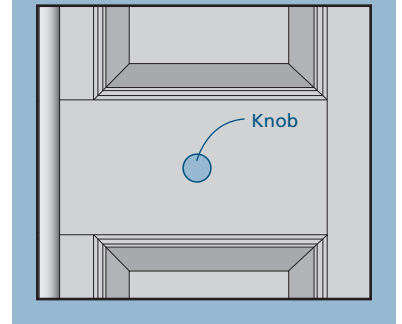

12. If not already finished, finish all 6 sides of the doors with an even number of coats on all surfaces.
13. Install any trim around the opening as desired.

Please visit jeld-wen.com/resources for finishing instructions, warranty and care and maintenance information.

Thank you for choosing